

Write your name here

Surname	Other names
---------	-------------

**Pearson Edexcel**  
**International GCSE**

Centre Number

--	--	--	--	--

Candidate Number

--	--	--	--

# Mathematics B

## Paper 1



Thursday 26 May 2016 – Morning  
**Time: 1 hour 30 minutes**

Paper Reference  
**4MB0/01**

**You must have:** Ruler graduated in centimetres and millimetres, protractor, compasses, pen, HB pencil, eraser, calculator. Tracing paper may be used.

Total Marks

### Instructions

- Use **black** ink or ball-point pen.
- **Fill in the boxes** at the top of this page with your name, centre number and candidate number.
- Answer **all** questions.
- Answer the questions in the spaces provided – *there may be more space than you need.*
- **Calculators may be used.**

### Information

- The total mark for this paper is 100.
- The marks for **each** question are shown in brackets – *use this as a guide as to how much time to spend on each question.*

### Advice

- Read each question carefully before you start to answer it.
- Check your answers if you have time at the end.
- Without sufficient working, correct answers may be awarded no marks.

Turn over ►

P45919A

©2016 Pearson Education Ltd.

1/1/1/1/1/



**PEARSON**

**Answer ALL TWENTY EIGHT questions.**

**Write your answers in the spaces provided.**

**You must write down all the stages in your working.**

- 1 Calculate the gradient of the line joining the points with coordinates  $(-3, -4)$  and  $(6, -1)$ .

.....  
**(Total for Question 1 is 2 marks)**

- 2 Factorise completely  $18x^2 - 2y^2$

.....  
**(Total for Question 2 is 2 marks)**

- 3 In 1964 the high jump world record for women was 1.91 metres.  
In 1987 it was 2.09 metres.

Calculate, to 3 significant figures, the percentage increase in this world record between 1964 and 1987.

.....%  
**(Total for Question 3 is 2 marks)**

DO NOT WRITE IN THIS AREA

DO NOT WRITE IN THIS AREA

DO NOT WRITE IN THIS AREA



DO NOT WRITE IN THIS AREA

DO NOT WRITE IN THIS AREA

DO NOT WRITE IN THIS AREA

4 Simplify  $\frac{36a^2b^5}{4a^3b^2}$

.....  
**(Total for Question 4 is 2 marks)**

5 The bearing of Nashik from Surat is  $142^\circ$   
Find the bearing of Surat from Nashik.

.....  
**(Total for Question 5 is 2 marks)**

6 Given that  $f(x) = 3 - 2x$   
find  $ff(x)$  in terms of  $x$ . Simplify your answer.

$ff(x) =$  .....  
**(Total for Question 6 is 2 marks)**



7  $\mathcal{E} = \{a, b, c, d, e, f, g, h, i, j\}$

$A = \{a, b, c, d, e\}$

$B = \{a, c, e, g, i\}$

Find  $(A \cup B)'$

(Total for Question 7 is 2 marks)

8

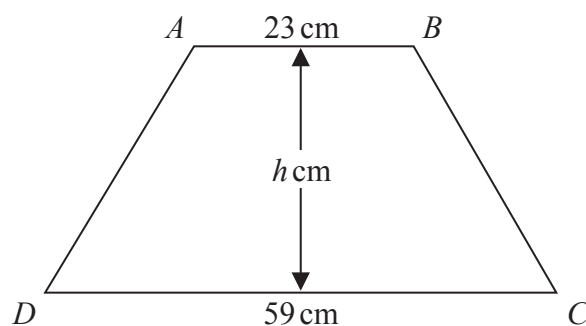

Diagram NOT accurately drawn

$ABCD$  is a trapezium with  $AB$  parallel to  $DC$ .

$AB = 23$  cm,  $DC = 59$  cm and the area of  $ABCD$  is  $574$  cm<sup>2</sup>

Given that  $h$  cm is the height of the trapezium, find the value of  $h$ .

$h =$  .....

(Total for Question 8 is 2 marks)

9 Write  $\frac{3}{x} - \frac{5}{2x}$  as a single fraction. Simplify your answer.

(Total for Question 9 is 2 marks)



DO NOT WRITE IN THIS AREA

DO NOT WRITE IN THIS AREA

DO NOT WRITE IN THIS AREA

10  $p^2 = 3x - 1$

Simplify  $2p^2 - 6x + 7$

.....  
(Total for Question 10 is 2 marks)

11 The mass  $M_e$  of the Earth is  $5.9722 \times 10^{24}$  kg  
The mass  $M_j$  of the planet Jupiter is  $1.8981 \times 10^{27}$  kg

(a) Find the value of  $\frac{M_j}{M_e}$  to the nearest integer.

.....  
(1)

(b) Express your answer to part (a) in standard form.

.....  
(2)

(Total for Question 11 is 3 marks)

12 Solve the equation  $2(3x - 4) - 4(1 - 3x) = 3(x + 4)$   
Show clear algebraic working.

$x =$  .....

(Total for Question 12 is 3 marks)



13 Given that  $x:y = 5:8$  and that  $y:z = 6:7$ , find  $x:z$

Give your answer in its simplest form.

$x:z = \dots\dots\dots$

(Total for Question 13 is 3 marks)

14

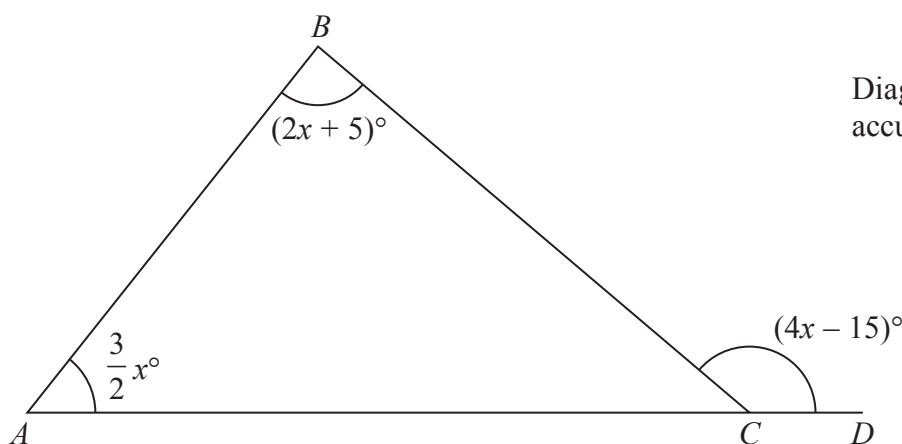

Diagram NOT accurately drawn

$ABC$  is a triangle and  $ACD$  is a straight line.

$$\angle BAC = \frac{3}{2}x^\circ, \angle ABC = (2x + 5)^\circ \text{ and } \angle BCD = (4x - 15)^\circ$$

Find the value of  $x$ .

$x = \dots\dots\dots$

(Total for Question 14 is 3 marks)



DO NOT WRITE IN THIS AREA

DO NOT WRITE IN THIS AREA

DO NOT WRITE IN THIS AREA

15 Two non-zero vectors  $\mathbf{a}$  and  $\mathbf{b}$  are not parallel.

Given that  $n\mathbf{a} + m\mathbf{b} = \mathbf{b} + 2m(\mathbf{a} - \mathbf{b})$ , where  $m$  and  $n$  are scalars, find the value of  $m$  and the value of  $n$ .

$m = \dots\dots\dots$

$n = \dots\dots\dots$

(Total for Question 15 is 3 marks)

16 Find the largest integer,  $x$ , such that  $\frac{1}{2}(2x + 1) > 3x - 5$

$\dots\dots\dots$

(Total for Question 16 is 3 marks)



17 Given that  $\sqrt{(x^2 + 9)} = x + y$   
find  $x$  in terms of  $y$

$x = \dots\dots\dots$

(Total for Question 17 is 4 marks)

18 Here are 8 numbers

5.9      6.3      6.7      6.9      7.5      8.1      8.1      8.9

(a) Find the median of the 8 numbers.

$\dots\dots\dots$   
(2)

(b) Calculate the mean of the 8 numbers.

$\dots\dots\dots$   
(2)

(Total for Question 18 is 4 marks)





19

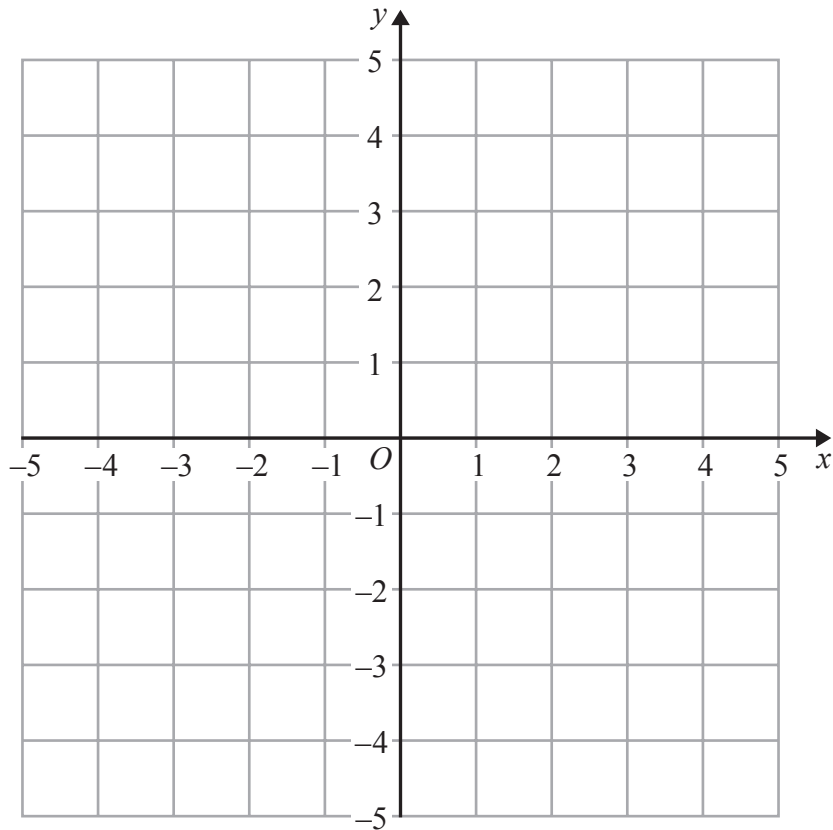

- (a) On the grid, draw and label
- (i) the line with equation  $y = -x$
  - (ii) the line with equation  $y = x + 2$

(2)

$ABCDE$  is a pentagon. The pentagon has the line with equation  $y = -x$  as its axis of symmetry. The point  $A$  has coordinates  $(3, 0)$ , the point  $D$  has coordinates  $(-4, 4)$  and the point  $E$  has coordinates  $(1, 3)$ .

- (b) Find the coordinates of  $B$  and the coordinates of  $C$ .

$B$  (....., .....

$C$  (....., .....

(2)

(Total for Question 19 is 4 marks)

Do NOT write in this space



20  $y$  varies inversely as the cube of  $x$

$$y = 256 \text{ when } x = \frac{1}{2}$$

Find the value of  $x$  when  $y = \frac{4}{27}$

$$x = \dots\dots\dots$$

(Total for Question 20 is 4 marks)

21 The  $n$ th term of a sequence is given by  $u_n = 2^n$  where  $n = 1, 2, 3, 4, \dots$

(a) Write down the first four terms of this sequence.

.....  
(2)

(b) Find the value of  $\frac{u_{500}}{u_{488}}$  giving your answer as a power of 8

.....  
(3)

(Total for Question 21 is 5 marks)



- 22 A particle  $P$  is moving along a straight line. At time  $t$  seconds ( $t \geq 0$ ), the displacement,  $s$  metres, of  $P$  from a fixed point  $O$  of the line is given by

$$s = \frac{5}{3}t^3 - \frac{9}{2}t^2 - 2t$$

At time  $t$  seconds, the velocity of  $P$  is  $v$  m/s.

- (a) Find an expression for  $v$  in terms of  $t$ .

$$v = \dots\dots\dots$$

(2)

- (b) Find the value of  $t$  when  $P$  is instantaneously at rest.

$$t = \dots\dots\dots$$

(3)

(Total for Question 22 is 5 marks)



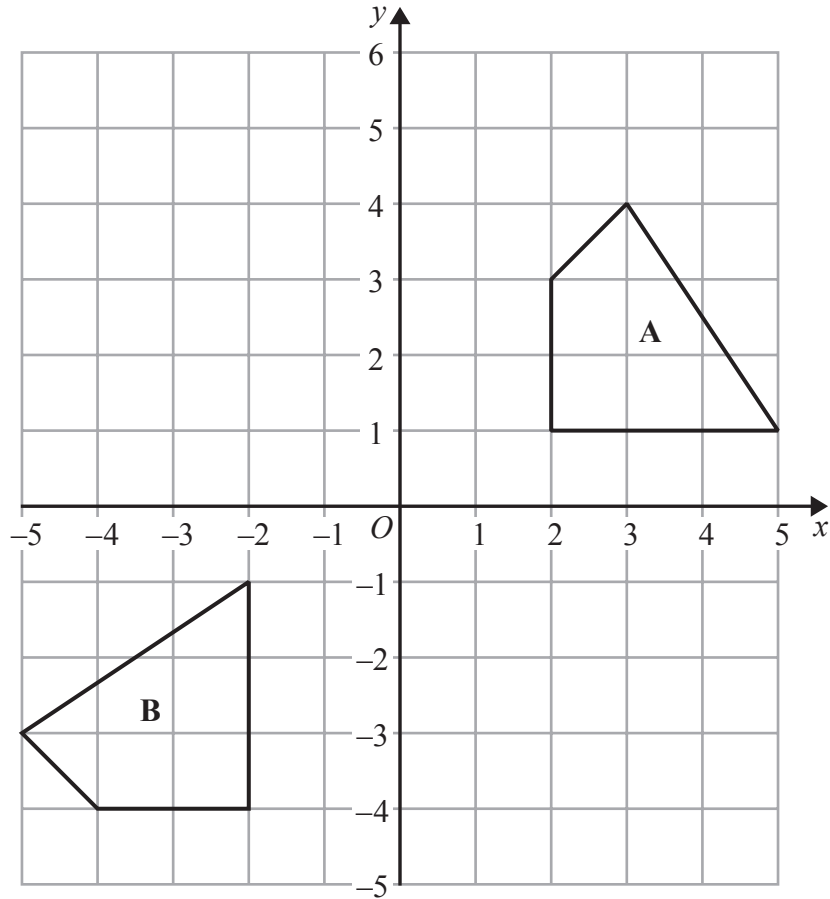

Quadrilateral **A** is transformed to quadrilateral **B** by an anticlockwise rotation about the origin followed by a translation.

(a) Write down the angle of rotation.

.....  
(1)

(b) Find the  $2 \times 2$  matrix which represents this rotation.

$\left( \begin{array}{cc} & \\ & \end{array} \right)$   
(2)

DO NOT WRITE IN THIS AREA

DO NOT WRITE IN THIS AREA

DO NOT WRITE IN THIS AREA



(c) Find the column vector which represents the translation.

$\begin{pmatrix} \phantom{0} \\ \phantom{0} \end{pmatrix}$

(2)

(Total for Question 23 is 5 marks)

Do NOT write in this space

DO NOT WRITE IN THIS AREA

DO NOT WRITE IN THIS AREA

DO NOT WRITE IN THIS AREA



P 4 5 9 1 9 A 0 1 3 2 0

DO NOT WRITE IN THIS AREA

DO NOT WRITE IN THIS AREA

DO NOT WRITE IN THIS AREA

24 Given that for all values of  $x$ ,

$$6x^3 - 19x^2 - 26x + 24 = (6x^2 + kx - 6)(x - 4) \quad \text{where } k \text{ is a constant,}$$

(a) show that  $k = 5$

(2)

(b) Hence factorise completely  $6x^3 - 19x^2 - 26x + 24$

(3)

(Total for Question 24 is 5 marks)

Do NOT write in this space



DO NOT WRITE IN THIS AREA

DO NOT WRITE IN THIS AREA

DO NOT WRITE IN THIS AREA

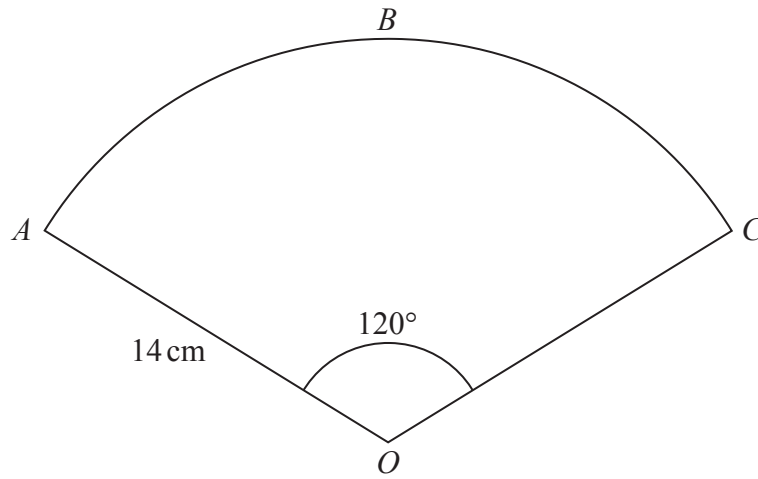

Diagram NOT accurately drawn

The diagram shows a piece of card in the shape of a sector,  $OABC$ , of a circle of radius 14 cm and centre  $O$ . The arc  $ABC$  subtends an angle of  $120^\circ$  at the centre of the circle.

(a) Calculate the length, in cm to 3 significant figures, of the arc  $ABC$ .

..... cm  
(2)

A hollow right circular cone is formed by joining  $OA$  and  $OC$  together.

Calculate, in cm to 3 significant figures,

(b) the radius of the cone,

..... cm  
(2)

(c) the height of the cone.

..... cm  
(2)

(Total for Question 25 is 6 marks)



26 The probability that it rains on any morning in the town of *Lloviendo* is  $\frac{1}{3}$

If it is raining on a morning, the probability that Maria goes for a run is  $p$

If it is not raining on a morning, the probability that Maria goes for a run is  $\frac{4}{5}$

(a) Complete the probability tree diagram.

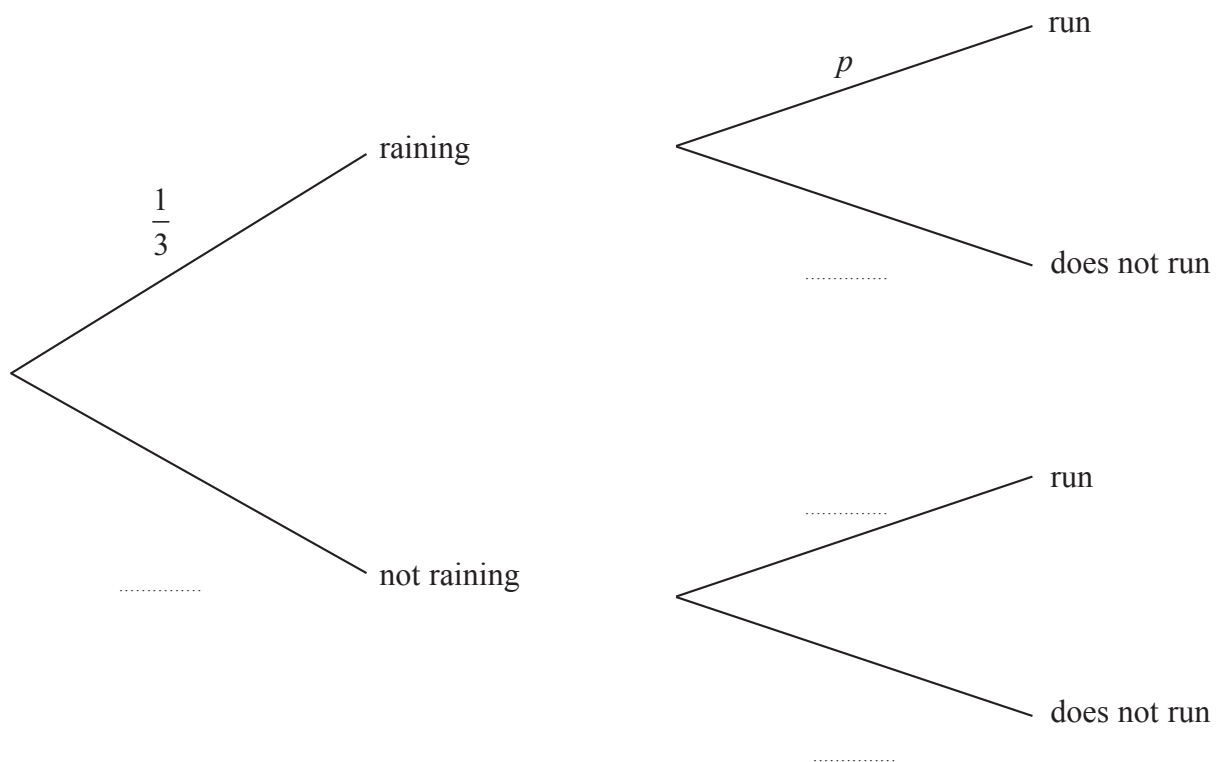

(3)





DO NOT WRITE IN THIS AREA

DO NOT WRITE IN THIS AREA

DO NOT WRITE IN THIS AREA

The probability that Maria goes for a run on any morning is  $\frac{37}{60}$

(b) Using your tree diagram and this information, form an equation in  $p$

.....  
(2)

(c) Find the value of  $p$

$p =$  .....  
(2)

**(Total for Question 26 is 7 marks)**

**Do NOT write in this space**



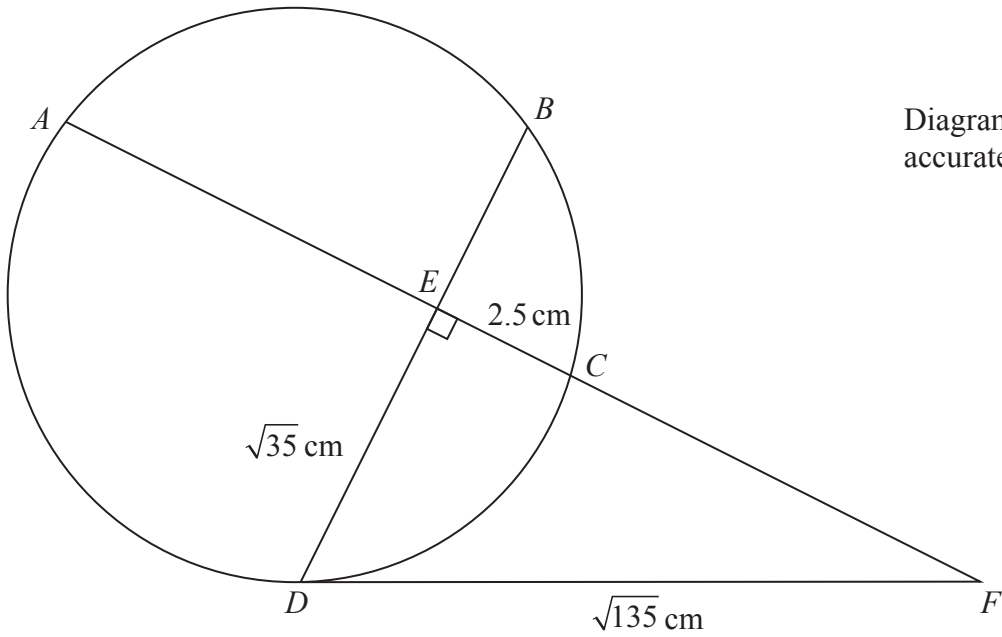

Diagram NOT accurately drawn

$ABCD$  is a circle. The chords  $AC$  and  $DB$  intersect at right angles at the point  $E$ . The point  $F$  is such that  $AECF$  is a straight line and  $FD$  is the tangent to the circle at  $D$ .

$EC = 2.5$  cm,  $DE = \sqrt{35}$  cm and  $DF = \sqrt{135}$  cm.

(a) Calculate the length, in cm, of  $EF$ .

..... cm  
(2)

(b) Show that  $AE = 8$  cm.

(3)



(c) Calculate the length, in cm to 3 significant figures, of  $EB$ .

DO NOT WRITE IN THIS AREA

DO NOT WRITE IN THIS AREA

DO NOT WRITE IN THIS AREA

..... cm

(2)

(Total for Question 27 is 7 marks)

Do NOT write in this space

Turn over for Question 28



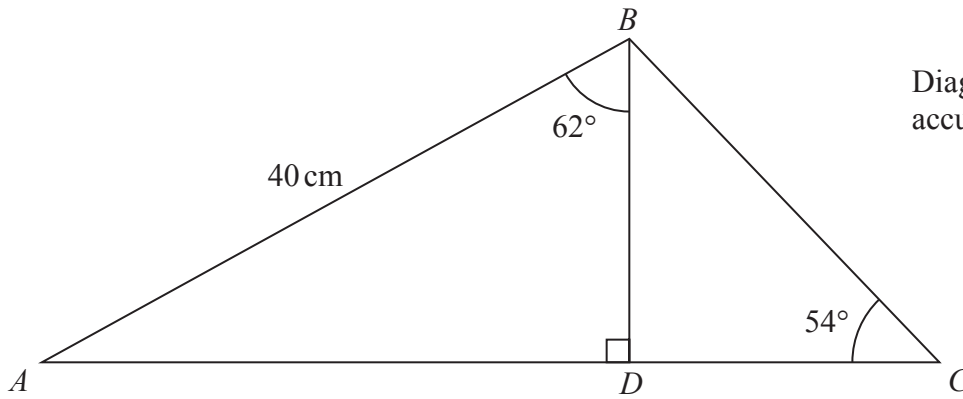

Diagram **NOT**  
accurately drawn

DO NOT WRITE IN THIS AREA

DO NOT WRITE IN THIS AREA

DO NOT WRITE IN THIS AREA

$ABC$  is a triangle.

$D$  is the point on  $AC$  such that  $BD$  is perpendicular to  $AC$ .

$AB = 40 \text{ cm}$ ,  $\angle ABD = 62^\circ$  and  $\angle BCD = 54^\circ$

Calculate the area, in  $\text{cm}^2$ , of triangle  $ABC$ . Give your answer to 3 significant figures.

.....  $\text{cm}^2$

(Total for Question 28 is 6 marks)

**TOTAL FOR PAPER IS 100 MARKS**

